

PRF-RO

At last, there's an innovation that offers customers an abundant supply of RO water, without the need or electric pumps or bulky storage tanks.

The Pentair Water® Reverse Osmosis System delivers up to hundreds of liters per day using typical line pressure, which eliminates the need for a supplemental pump in most applications. That's enough capacity for many small commercial applications, at the price of a residential system. The Pentair Water RO features a continuous flow design, so there's no need to clear space for a storage tank.

Profitably sell quality water systems for kitchens or across a full range of commercial settings:

- Steamers
- Coffee makers
- Photography processing
- Water coolers
- Business offices
- Restaurants
- Humidifiers
- Aquariums
- Misters
- Pubs
- Many more profitable possibilities

Pro Quality That's Right At Home

By pursuing new opportunities in light of commercial installations, you'll open more customer doors with the Pentair Water® Reverse Osmosis System.

Customers will love the convenience of purer, more refreshing water without the need to rearrange their spaces for pumps and tanks. Customers get a compact, reliable system that better suits the flow requirements of small and mid-sized businesses, at a cost that's a fraction of what they'd pay for most commercial RO systems.

The profitability doesn't stop on installation day. Replacement filters are available only from Pentair Water dealers like you, so each RO system is an open door to new customer opportunities for years to come.



Features and Benefits

- **Continuous Flow** - No storage tank needed
- **Works with Line Pressure** - > 2.76 bar / 40 psi
- **No Pump or Electricity**
- **Never Runs Dry** - On-demand flow system will create hundreds of liters per day
- **Consistent Membrane Efficiency**
- **High Recovery System** - Less wasted water goes down the drain
- **Tough Stuff** - Constructed of high impact plastic for years of dependability
- **Virtually Maintenance Free** - Change cartridges fast and easy - no scrubbing or cleaning
- **No Tanks!** - Never again worry about contamination or loss of tank pressure.
- **Sleek Styling** - Distinctive appliance-style design appeals to customers.
- **Complete Product Literature and Training Support**

Installation's a Snap

Quick latch snaps into place and locks down all four tubing connections in one easy step.

Steady Stream of Income

Replacement parts, filters are available only through professional channels.

Never Runs Dry

Continuous flow provides up to hundreds of liters per day.

Refreshment on Tap

Custom high-flow faucet (with air gap) custom made for this system.

Snug Size

Compact, upright profile has a small footprint and needs no fancy mounting.

Pentair Water® Reverse Osmosis System



System Comparison		
	Pentair Water RO	Standard RO
Average Daily Production Rate	Hundreds of liters	37,9-189 LPD (10-50 GPD)
Water Storage Tank	Optional	Integral part of system
System Efficiency*	22.7%	As little as 5%

* Efficiency rating is identical to recovery rating when the system is tested without a storage tank or when a storage tank is bypassed.

Minimum and Maximum Operating Conditions		
Condition**	Minimum	Maximum
Inlet Pressure	2.76 bar (40 psi)	5.52 bar (80 psi)
Inlet Temperature	4.44°C (40°F)	37.78°C (100°F)
Inlet TDS	50 mg/L	2,000 mg/L
Inlet Hardness	0 mg/L - (0 grain)	171 mg/L - (10 grain)
Inlet Chlorine	0 mg/L	1.0 mg/L
Inlet Iron	0 mg/L	0.1 mg/L
Inlet Manganese	0 mg/L	0.05 mg/L

**System is designed for use on potable water sources only.

Tubing/Fitting Dimensions	
Inlet Tubing	1.22 meters of 12.7 mm natural tubing (4 feet of 1/2" natural tubing)
Concentrate Tubing	1.22 meters of 9.53 mm black tubing (4 feet of 3/8" black tubing)
Permeate Tubing	1.22 meters of 9.53 mm blue tubing (4 feet of 3/8" blue tubing)
Drain Tubing (for airgap installation)	0.91 meters of 12.7 mm red tubing (3 feet of 1/2" red tubing)
Drain Connection	9.53 mm or 12.7 mm (3/8" or 1/2")
Carbon Post-Filter	9.53 mm quick disconnect fittings (3/8" quick disconnect fittings)

Inlet Connectors	
Option 1	12.7 mm x 12.7 mm x 12.7 mm tee (1/2" x 1/2" x 1/2" tee)
Option 2	15.875 mm x 15.875 mm x 12.7 mm tee (5/8" x 5/8" x 1/2" tee)
Option 3	12.7 mm x 12.7 mm threaded x 12.7 mm tee (1/2" x 1/2" threaded x 1/2" tee)
Option 4	15 mm x 15 mm x 12.7 mm tee (0.59" x 0.59" x 1/2" tee)

Filter/Membrane Performance Specifications				
Dimensions				
Filter Type	Length	Diameter	Flow Rate***	Average Life
Carbon Pre-Filter	43.2 cm (17.0")	7.4 cm (2.9")	14.2 LPM (3.75 GPM)	6-12 months, 37,850 liters (10,000 gal)
RO Element	47.6 cm (18.75")	8.0 cm (3.16")	0.95 LPM (0.25 GPM)	2-4 years
Carbon Post-Filter	25.4 cm (10.0")	5.1 cm (2.0")	2.8 LPM (0.75 GPM)	6-12 months

***Based on internal testing data.

Pentair Water® Reverse Osmosis System



Outline Dimensions in Inches (mm)

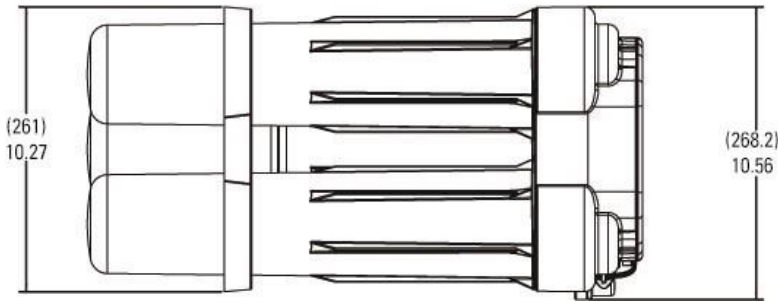
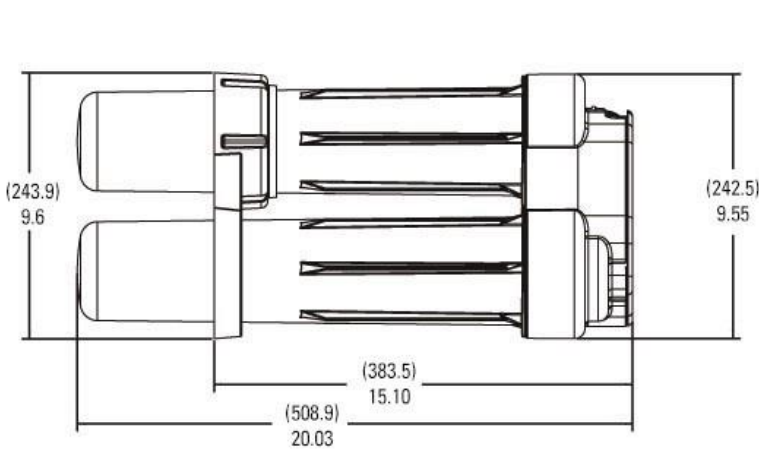

Performance - Flow Rate Characteristics*

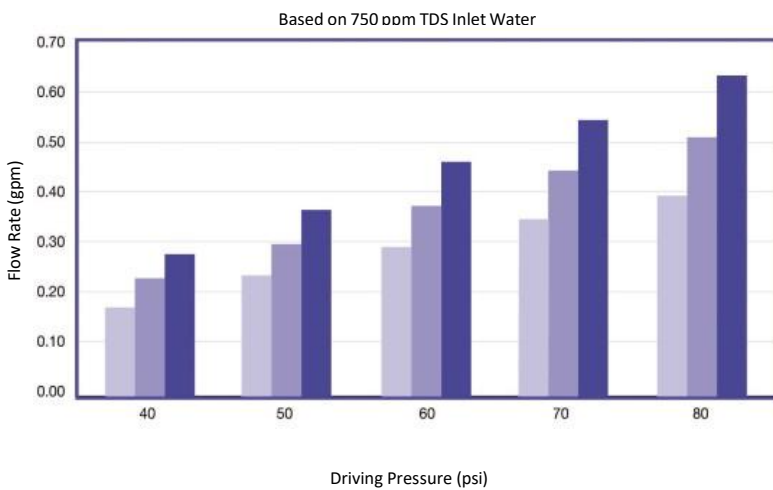

Flow Adjustment Based on TDS
 Estimated Flow Change from 750ppm NaCl/RO = $-0.0002 \text{ (TDS)} + 0.15$
 *Estimated flow based on internal test data. Actual performance may vary.